

Glass – Fixed Rear Quarter Window – Remove and Install (42 514 0)

Proprietary Tools

| |
|--|
| Fein cutter blade No. 6 39 03 143 01 3 |
| Fein cutter blade No. 6 39 03 113 02 2 |

Equipment

| | |
|-------------------------|--------------|
| Fein Oscillating Cutter | FDEP 2583391 |
| Hot air gun | FDEP 1561950 |
| Mixing/Applicator Gun | FDEP 2650730 |

⚠ WARNING: Always wear gloves and eye protection when working with the glass cutting tool as the cutting operation may produce splinters. Ear defenders should be worn when using the Fein cutter.

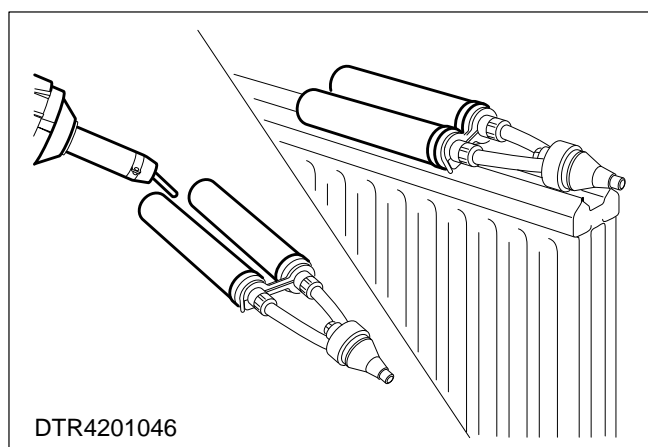

Remove

NOTE: Should the ambient temperature fall below 10°C, heat the cartridges for approximately 15 minutes by placing them on a warm radiator, or by using a heat gun set at approximately 25°C.

1. Heat the adhesive if required.
2. Locally remove the rear door weatherstrip (refer to Operation Number 41 644 0).
3. Drill out the rivet.
4. Remove the bolster (refer to Operation Number 40 135 0).
5. Remove the C-pillar trim (refer to Operation Number 43 618 0).
6. Remove the rear seat belt reel assembly (refer to Operation Number 40 240 0).

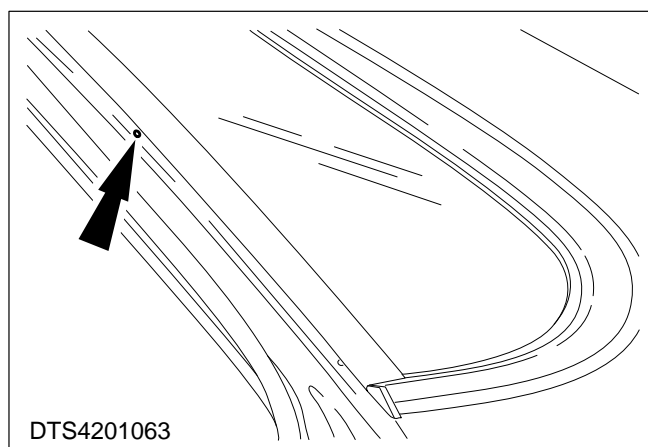

7. Remove the two window fixing nuts.

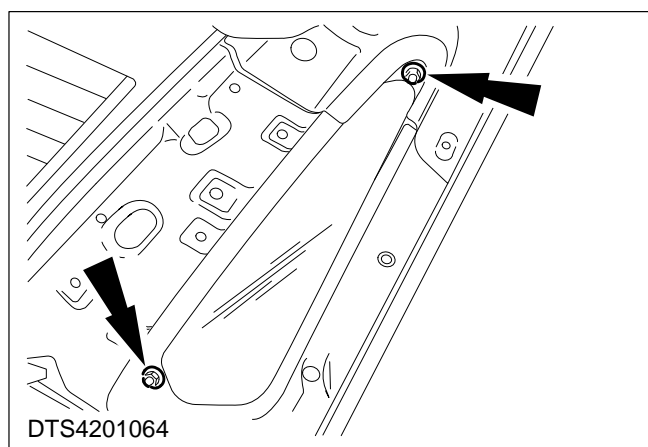

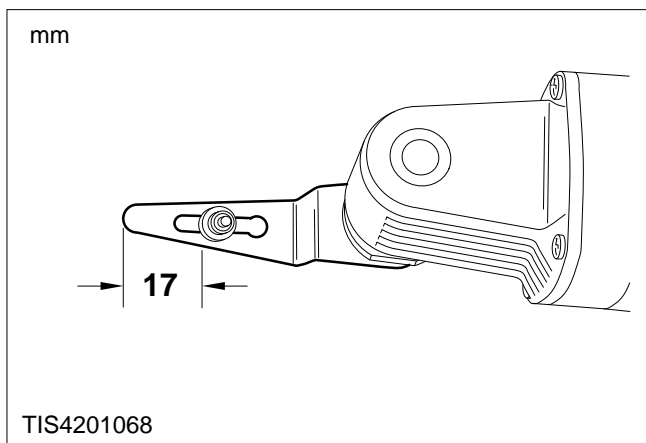

8. Cut out the rear quarter window from inside the vehicle.

Fit blade number 63903143013 set to 17mm to cut out the glass.

9. Carefully remove the glass.

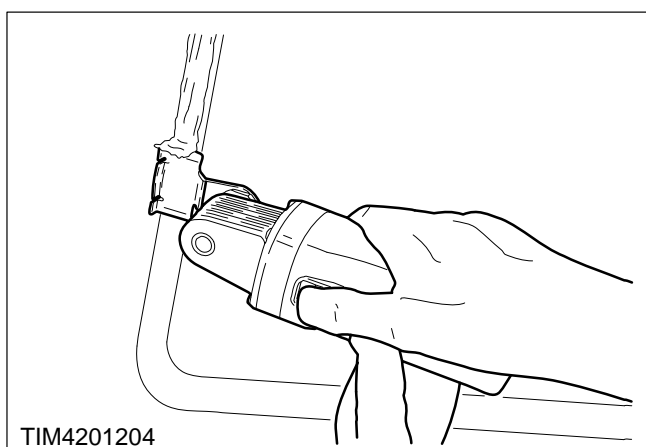

Install

⚠ CAUTION: Avoid touching the trimmed surface as this will inhibit the new adhesive from bonding.

10. Remove the excess PU adhesive from the aperture using the Fein cutter fitted with blade number 6 39 03 113 02 2.

Carefully trim the remaining PU adhesive from the window aperture to leave approximately 1 mm of trimmed PU adhered to the bodywork.

11. If the original glass is to be refitted, remove the excess PU adhesive from the glass as described in the previous step.

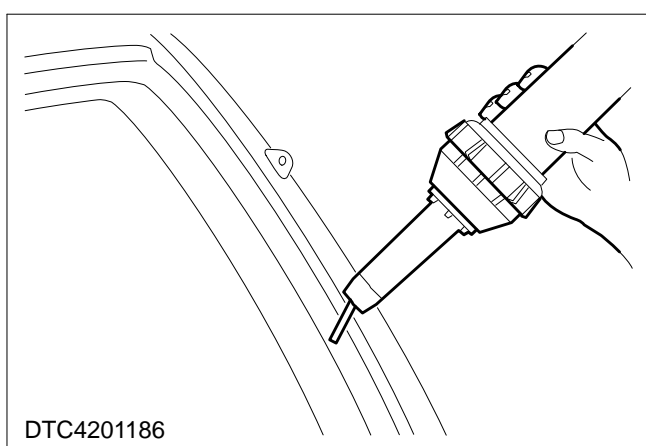

⚠ WARNING: To ensure that the PU adhesive cures, it is essential that all bonding surfaces are free of all moisture.

12. Using a heat gun, apply warm air (25 °C) to the window aperture and glass bond line to remove all traces of moisture.

13. Prepare the glass, window aperture and trimmed PU adhesive in accordance with the instructions supplied with the adhesive kit.

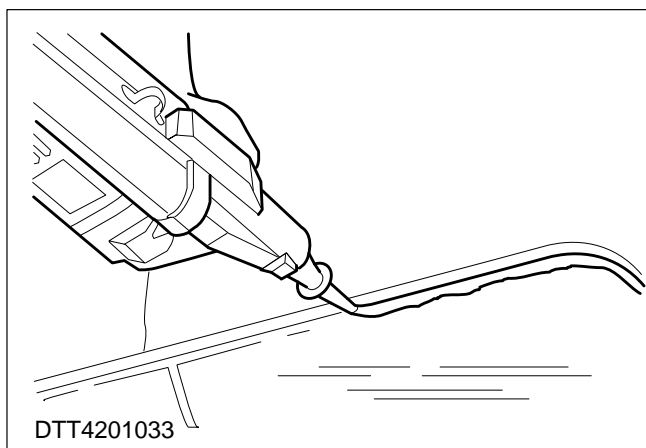

NOTE: Discard the first 10 cm of PU adhesive as this may have a reduced working time.

NOTE: To avoid water leaks, any breakage in the continuous bead should be overlapped by 20 mm.

14. Apply the PU adhesive in a continuous bead of between 8 and 10 mm height to the rear quarter window flange along the bond line.

15. Fit the rear quarter window.

- With the aid of another technician, use suction pads to carefully lift the glass and align it in position over the aperture flange.
- Firmly and evenly press the glass into position.

16. Refit the remaining components in reverse order.

17. Check for leaks and correct as necessary.